

MOTORCYCLE WINDSHIELDS



List of contents

Inhalt

ORIGINAL / STANDARD SHAPED SCREEN <i>Originalformscheibe</i>	4	SCREENS FOR NAKED BIKES <i>Roadshield Classic</i>	23
SPOILER SCREEN <i>Spoilerscheibe</i>	5	SCREENS FOR NAKED BIKES <i>Speedscreen</i>	24
TOURING SCREEN <i>Tourenscheibe</i>	6	SCREENS FOR NAKED BIKES <i>Racingscreen for Naked Bikes</i>	25
SPORT SCREEN <i>Sportscheibe</i>	7	SCREENS FOR NAKED BIKES <i>Varioscreen for Naked Bikes</i>	26
RACING / DOUBLE-BUBBLE SCREEN <i>Racingscheibe</i>	9	SCREENS FOR NAKED BIKES <i>Vario-Touringscreen for Naked Bikes</i>	27
ABOUT X-CREEN <i>Über X-creen</i>	10	SCREENS FOR NAKED BIKES <i>V-Flow Screen</i>	28
X-CREEN SPORT <i>X-creen Sport</i>	12	SCREENS FOR NAKED BIKES <i>Highwayshield</i>	30
X-CREEN TOUR <i>X-creen Tour</i>	13	SCREENS FOR NAKED BIKES <i>Customshield</i>	31
VARIOSCREEN <i>Varioscreen</i>	14	PRODUCT OVERVIEW <i>Produktübersicht</i>	32
VARIO-TOURINGSCREEN <i>Vario-Touringscreen</i>	15	ABOUT US <i>Über uns</i>	34
TOURINGSCREEN ARIZONA <i>Tourenscheibe Arizona</i>	16	<i>Faces</i> <i>Das MRA-Team</i>	36
NAKED SPECIAL N <i>Naked Special N</i>	18	SOCIAL MEDIA <i>Soziale Netzwerke</i>	37
SCREENS FOR NAKED BIKES <i>Scheiben für unverkleidete Motorräder</i>	20	ONLINE-SHOP <i>Online-Shop</i>	38
SCREENS FOR NAKED BIKES <i>Streetshield</i>	21	MRA WORLDWIDE <i>MRA Weltweit</i>	39
SCREENS FOR NAKED BIKES <i>Roadshield</i>	22		



ORIGINAL / STANDARD SHAPED SCREEN Originalformscheibe

Original shaped screen

Shape, profile and size match your bike's original screen. Available in all MRA-colors.

Originalformscheibe

Form und Größe entsprechen der Originalscheibe. In allen MRA-Farben erhältlich.



Spoiler Screen

This type of screen matches the original around its base and, typically, is also similar in length, but with the addition of a small spoiler section at its upper rear edge is normally slightly taller than standard. Available in all MRA-colors.

Spoilerscheibe

Die Spoilerscheibe entspricht der Originalscheibe, hat aber am hinteren Ende eine kleine Abrisskante. In allen MRA-Farben erhältlich.



Touring Screen

The Touring Screen has a similar shaped base as your bike's standard screen but, typically, is longer and taller. Its extra length and height is created by an upwardly sloping rear section over its entire width, designed to deflect wind pressure away from the rider, ensuring an easy, relaxing ride - even on long trips. For some models with very upright screens as standard, to avoid creating unnecessary turbulence, the Touring Screen is just simply extended without any further upwards angle. Available in all MRA-colors.

Tourenscheibe

Die Tourenscheibe hat die Form wie die Originalscheibe, jedoch zusätzlich am hinteren Ende einen nach oben geneigten Windabweiser über die ganze Breite. Dadurch wird der Winddruck vom Oberkörper genommen und ein entspanntes Fahren ermöglicht, auch auf langen Touren. Bei einigen Modellen, die eine steil stehende Scheibe haben, ist der Windabweiser nur als Verlängerung ausgebildet und nicht nach oben geneigt, um Turbulenzen zu vermeiden. In allen MRA-Farben erhältlich.



CB 500X T8



Caponord T8



PCX 125 T1



F700 GS T0



R1200 GS T1

Sportscreen

The Sportscreen is a shortened version of the original screen and gives the motorcycle or scooter a modern, sporty look.

Die Sportscreen ist eine gekürzte Version der Originalscheibe und gibt dem Motorrad/Scooter ein modernes, sportliches Aussehen.



T-Max SP8



PCX 125 SP8



Multistrada SP1



XT 1200Z SP8



Supermoto SP8



Tiger 1200 Explorer SP8

MRA RACING

MRA Rennsport

MRA is rooted in racing. We factory closely with many national and international racing teams. So don't be suprised to see teams in MOTO-GP, Superbike and Endurance using MRA windscreens. Gilera, Derbi, Kawasaki, Yamaha and Suzuki are just a few well-known examples. But MRA doesn't just provide equipment. We also sponsor serveral well-established drivers in additon to promising new teams and Cups.

MRA hat seine Wurzeln im Rennsport. Viele Rennteams auf nationaler wie internationaler Ebene arbeiten mit uns zusammen. So werden Teams aus Moto-GP, Super-bike und Endurance wie Gilera, Derbi, Kawasaki, Yamaha, Suzuki, etc mit MRA-Scheiben ausgerüstet. Neben Technik-Ausrüster tritt MRA auch als Sponsor auf und unterstützt dadurch neben etablierten Fahrern auch Nachwuchs- und Markencups.



Racing /Double-Bubble Screen

This type of screen was originally developed by MRA for competition and is used today by many high-level racers including works MotoGP teams. The lower part of the Racing Screen corresponds to the original profile, but with a bubble-shaped extension in the centre to improve aerodynamics and deflect wind pressure away from your helmet. Available in all MRA-colors.

Racingscheibe

Diese Scheibenform wurde für den Rennsport entwickelt und wird von vielen Racing-Teams verwendet. Die Racingscheibe entspricht im unteren Teil der Originalscheibe, hat aber in der Mitte eine kuppelartige Erhöhung. Dadurch wird der Helm vom Winddruck entlastet und die Aerodynamik verbessert. In allen MRA-Farben erhältlich.



T-Max R8



CBR 1000RR R8



ER6F R1



CBR 600RR R8



Daytona 675 R8



ZX 300 Ninja R1



GSX-R 1000 R3



X-creek Sport

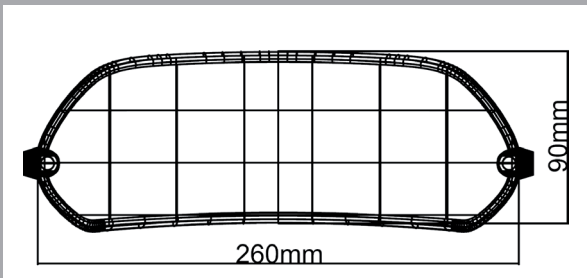
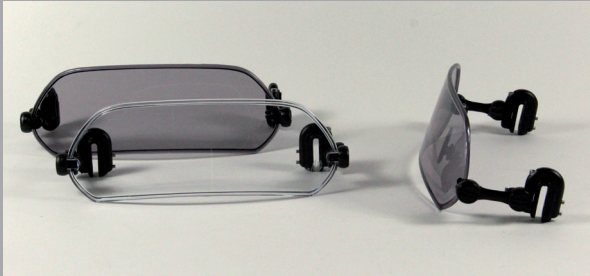

X-creek Tour

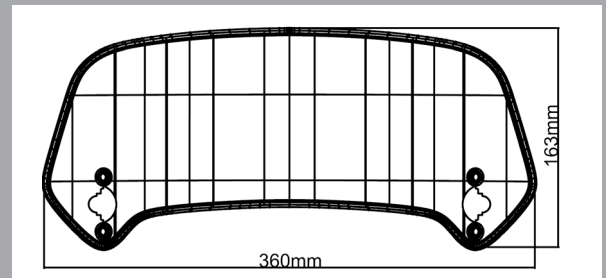
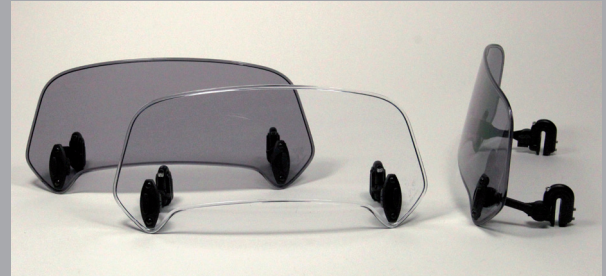

X-creeN: The revolutionary Spoiler system from MRA

X-creeN is a very variable adjustable spoiler that can be screwed or clamped to existing motorbike windscreens. There are two versions, each of them either colorless or tinted:

X-creeN Sport: for smaller scooters and sporty motorbikes. The small spoiler (size 260 x 90mm) can be adjusted in height, angle and distance to the windscreen via double joints and provides amazing relief from wind pressure - even on sporty motorbikes.

X-creeN Sport is an attachment spoiler that can be adjusted to almost every position. It can act as a windscreen enlargement with adjustable wind deflector and also as a diffuser in front of the windscreen that gently reduces the air flow or, if desired, directs the wind to the driver to refresh him on hot days. X-creeN Sport can either be clamped (e.g. for a holiday) or screwed and also has the ideal size for sporty motorbikes (available clear or smoked grey).

X-creeN Tour: for large scooters and touring motorbikes. The spoiler (size 360 x 163mm) can be mounted with a simple joint (angle adjustable) or a double joint (angle, distance to the windscreen and height can be adjusted by 110 mm) so that all desired effects from a slipstream to a gentle inflow through to a cooling breeze can be achieved.

X-creeN: Das revolutionäre Spoilersystem von MRA

X-creeN ist ein sehr variabel verstellbarer Spoiler, der auf vorhandene Scheiben geschraubt oder geklemmt werden kann. Es gibt zwei Ausführungen, jeweils in farblos oder getönt:

X-creeN Sport: für kleinere Scooter und sportliche Motorräder. Der kleine Spoiler (Größe 260 x 90mm) kann über Doppelgelenke in der Höhe, im Winkel und Abstand zur Scheibe verstellt werden und erreicht auch auf sportlichen Motorrädern eine erstaunliche Entlastung vom Winddruck.

X-creeN Sport ist ein Aufsatzspoiler, der sich in nahezu jede beliebige Position verstellen lässt. Er kann als Scheibenverlängerung mit verstellbarem Windabweiser ebenso fungieren, wie als Diffusor vor der Scheibe, der die Luftströmung sanft reduziert, oder wenn gewünscht, den Wind auf den Fahrer leiten, um an heißen Tagen zu erfrischen. X-creeN Sport kann wahlweise geklemmt (z.B. für einen Urlaub) oder verschraubt werden und hat auch für sportliche Motorräder die ideale Größe (lieferbar in farblos oder getönt).

X-creeN Tour: für große Scooter und Tourenmotorräder. Der Spoiler (Größe 360 x 163mm) kann mit einem einfachen Gelenk (Winkel verstellbar) oder Doppelgelenk (Winkel-, Abstand zur Scheibe und Höhe um 110mm verstellbar) montiert werden, sodass von Windschatten, über sanfte Anströmung bis hin zur kühlenden Brise alle gewünschten Wirkungen erzielt werden können.

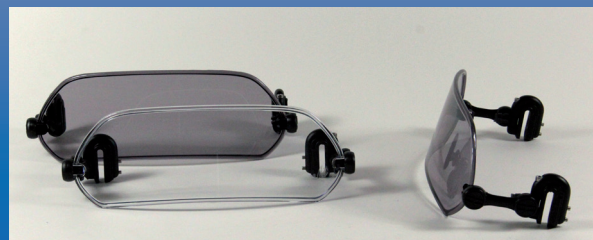

X-creeN Sport

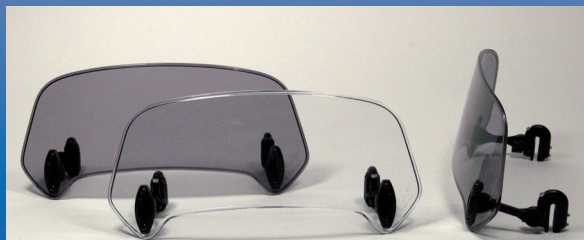

X-creeN Tour



X-creen Sport is an attachment spoiler that can be adjusted to almost every position. It can act as a windscreen enlargement with adjustable wind deflector and also as a diffuser in front of the windscreen that gently reduces the air flow or, if desired, directs the wind to the driver to refresh him on hot days.

X-creen Sport can either be clamped (e.g. for a holiday) or screwed and also has the ideal size for sporty motorbikes (available clear or smoked grey).

X-creen Sport ist ein Aufsatzspoiler, der sich in nahezu jede beliebige Position verstellen lässt. Er kann als Scheibenverlängerung mit verstellbarem Windabweiser ebenso fungieren, wie als Diffusor vor der Scheibe, der die Luftströmung sanft reduziert, oder wenn gewünscht, den Wind auf den Fahrer leiten, um an heißen Tagen zu erfrischen.

X-creen Sport kann wahlweise geklemmt (z.B. für einen Urlaub) oder verschraubt werden und hat auch für sportliche Motorräder die ideale Größe (lieferbar in farblos oder getönt).



X-creen Tour: The spoiler (size 360 mm x 163 mm) can be mounted with a simple joint (angle adjustable) or a double joint (angle, distance to the windscreen and height can be adjusted by 110 mm) so that all desired effects from a slipstream to a gentle inflow through to a cooling breeze can be achieved.

X-creen Tour: für große Scooter und Tourenmotorräder. Der Spoiler (Größe 360mm x 163mm) kann mit einem einfachen Gelenk (Winkel verstellbar) oder Doppelgelenk (Winkel-, Abstand zur Scheibe und Höhe um 110mm verstellbar) montiert werden, sodass von Windschatten, über sanfte Anströmung bis hin zur kühlenden Brise alle gewünschten Wirkungen erzielt werden können.



Varioscreen

The Vario Screen is in two-parts, the upper/front section of which can be adjusted in height by up to 5 cm, to find the optimum position for individual riders. Its special design provides an air inlet at the base of the front section, admitting a controlled flow of air behind the screen, providing a large reduction in wind pressure without creating excessive additional drag or turbulence. Available in clear and smoked grey.

Varioscreen

Die Varioscreen ist zweiteilig, wobei der obere Teil hinterströmt wird und in der Höhe um 5 cm verstellbar ist. Dadurch kann der Fahrer die Scheibe für sich optimal einstellen. Durch die Hinterströmung werden Turbulenzen vermieden. Erhältlich in klar und rauchgrau.



Tiger 800 V1



XL 1000V V1

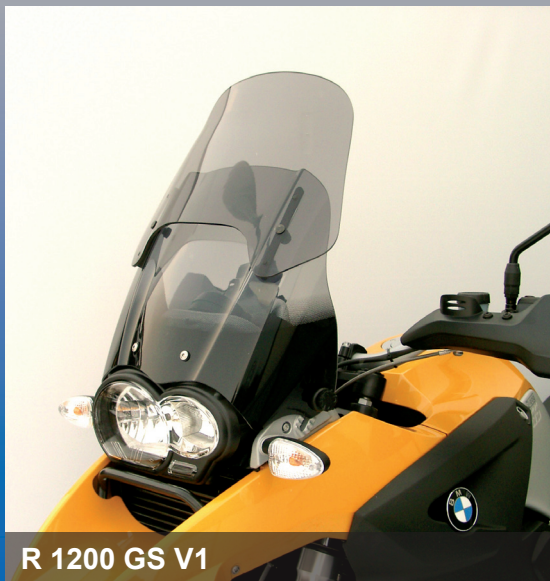

R 1200 GS V1



FJR 1300 VM1

Vario-Touringscreen

This advanced design of Touring screen has a uniquely mounted spoiler at its rear edge which, without the use of tools, can easily be adjusted into one of seven positions to suit your (and your passenger's) needs. Positioned on the top rear edge of the screen for maximum effect, the air current is spread out and slowed down, virtually eliminating turbulence. The result is airflow deflected away from the rider to allow a more relaxing, upright riding position, at high speed on long trips. Your passenger can also benefit from the improved airflow as the spoiler position can be adjusted to suit their needs too. Available in clear and smoked grey.

Vario-Touringscreen

Diese Tourenscheibe hat am Ende einen Spoiler, der sich manuell in sieben Stufen auf die gewünschte Position verstellen lässt. Durch die Hinterströmung des Spoilers wird der Winddruck vom Fahrer genommen und gleichzeitig die Turbulenzen reduziert. Die Vario-Touringscreen ist in klar und rauchgrau erhältlich.



R1200 GS VT1



CB 500X VT1



R1200 GS VT1



R1200 GS VT1

For Touring Bikes GTR 1000, R80/100 RT/LT, K75/100 RT/LT or Honda Goldwing we have developed the Touring Windscreen Arizona. This screen will give you the necessary protection while you are on the road. The scree is available in smoke grey and clear. The screen is also available for the K75/100 RT/LT with additional instrument console.

Für Tourenmaschinen GTR 1000, R80/100RT, K75/100 RT/LT oder Honda Goldwing haben wir die Tourenscheibe Arizona entwickelt. Sie liefert den nötigen Windschutz für Ihre Tourenfahrt. Diese Scheiben sind in klar und in rauchgrau erhältlich. Die Tourenscheibe Arizona ist auch bei vorhandener Zusatzinstrumentenkonsole bei der K75 / 100 RT/LT erhältlich.





We supply a range of individual screens to match the design and curves of each model in the increasingly popular generation of naked sports bikes. The screens use a specialised mounting kit for attachment to your bike, giving you more wind protection while improving your motorbike's general aesthetics.

Für die Generation der immer beliebter werdenden sportlichen Naked-Bikes bieten wir individuelle Scheiben an, die der Linienführung und dem Design des jeweiligen Motorrades folgen. Diese werden mit einem speziellen Befestigungssatz montiert. Somit erhalten Sie besseren Windschutz und optische Aufwertung Ihres Motorrades.

NR: Sports screen in a racing look with effective wind protection, designed to match to your motorbike's design and lines.

NS: Sports screen with a gentle spoiler for improved wind protection, in a design that perfectly matches your motorbike.

NT: Touring screen with ideal wind protection beautifully integrated into the motorcycle.

NVT: Touring screen with a spoiler that you can manually adjust in seven levels to the desired position, allowing you to fine-tune your wind protection to your requirements.

NR: Sportliche Scheibe im „Race-Look“ mit gutem Windschutz, die optimal zum Design und der Linienführung des Motorrades passt.

NS: Sportliche Scheibe mit leichtem Spoiler für besseren Windschutz und perfekt zum Motorrad passendem Design.

NT: Tourenscheibe mit optimalem Windschutz, die sich formschön in das Motorrad integriert.

NVT: Tourenscheibe mit Spoiler, der sich manuell in sieben Stufen auf gewünschte Positionen verstellen lässt, um den Windschutz optimal an die Wünsche des Fahrers anzupassen.





MT09 NR1



MT09 NR8



MT09 NVT1



MT09 NT1

We supply a variety of screens for your classical naked bike. All of our screens use our universal HK mounting kit with two clamps on the handlebar, and also special brackets for some models. The mounting kit attaches to your bike using a two-point bracket that allows easy screen mounting and replacement. The various ingenious options for handlebar mounting with benefits such as avoiding interference with your brake lines or sat nav in combination with the respective adjustable screen give you an individually adjustable solution for any motorbike.

Wouldn't want to do without a small sports screen such as our RNB racing screen in everyday biking? Need more wind protection such as our HI highway shield on longer trips? Just change the screen without dismantling the brackets.

Our screens are fitted with a smart ball joint for adjusting the screen to your requirements.

Naturally, we've had all of our screens tested by the German TÜV for performance at top speeds, and many of our models come with a German general operating permit or ABE.

Our screens are available in clear and smoke grey, and some are also available in blue and black.

Für die klassischen Naked Bikes haben wir verschiedene Scheibenvariationen im Angebot. Alle Scheiben werden mit unserem Universal-Haltersatz (HK) mit zwei Schellen am Rohrlenker befestigt. Für einige Modelle gibt es auch spezielle Halter. Der Haltersatz ist mit einer Zwei-Punkt-Halterung befestigt; dies ermöglicht den einfachen Anbau und Austausch unserer Scheiben. Durch die ausgeklügelten verschiedenen Befestigungsvarianten des Halters am Rohrlenker (z.B. um an Bremsleitungen oder Navi vorbeizukommen) in Kombination mit den jeweils verstellbaren Scheiben, erhalten Sie eine individuell anpassbare Lösung für jedes Motorrad.

Möchten Sie für die tägliche Fahrt eine kleine sportliche Scheibe nicht missen, z.B. unsere Racingscreen (RNB)? Wünschen Sie sich für längere Tourenfahrten jedoch mehr Windschutz, z.B. mit dem Highwayshield (HI)? Dann können Sie die Scheiben einfach austauschen - ohne den Halter zu demontieren.

Die Scheiben sind durch ein intelligentes Kugelgelenk individuell auf ihre Bedürfnisse einstellbar.

Selbstverständlich wurden alle Scheiben vom TÜV unter Höchstgeschwindigkeit getestet und haben für sehr viele Modelle ABE.

Die Scheiben sind in klar und rauchgrau erhältlich; einige Modelle zusätzlich auch in schwarz und blau.



Streetshield

A small screen that is ideal for enduros and roadsters. We have designed the screen with extra width to avoid turbulence at the sides. The screen is available in all MRA-colors.

Streetshield

Kleine Scheibe, die sich bestens für Enduros und Roadster eignet. Die Scheibe ist bewusst breit ausgefallen, um die seitlichen Turbulenzen zu vermeiden.

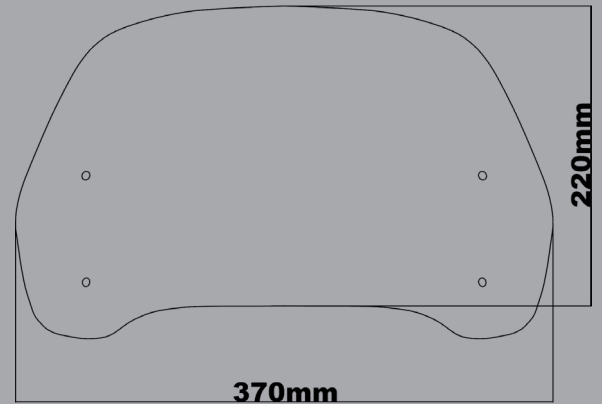

R 1200R ST1



R1200R ST1

Roadshield

A midsize screen that is ideal for enduros and roadsters. The screen is available in all MRA-colors.

Roadshield

Mittelgroße Scheibe, die sich für Enduros und Roadster eignet. Sie ist in allen MRA-Farben erhältlich.



MT 01 RO1

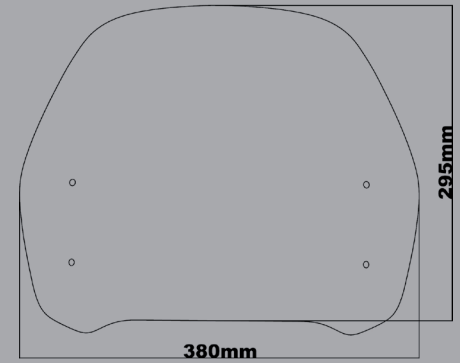
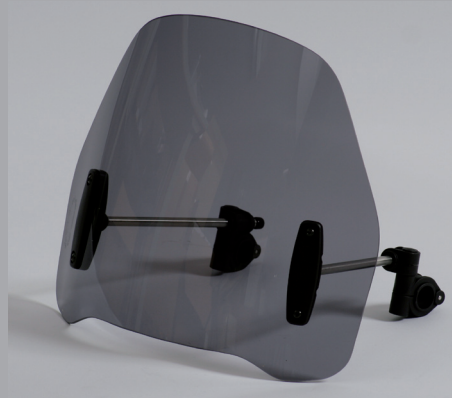

R1200 R RO1



R1200 R RO1

Road Shield Classic is a medium-sized screen with a round profile that creates an especially harmonious look on classical bikes.

Das Roadshield Classic ist eine mittelgroße Scheibe, die durch ihren runden Ausschnitt besonders an klassischen Bikes einen formvollendeten Eindruck hinterlässt.

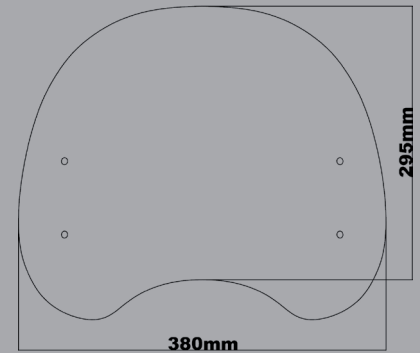

Speedscreen

Apart from its contemporary and very attractive design, the Speedscreen improves wind protection on all Naked Bikes. Available in all MRA-colors.

Speedscreen

Die Speedscreen bietet neben dem markanten, sportlichen Design einen besseren Windschutz für alle Naked-Bikes. Die Scheibe ist in allen MRA-Farben erhältlich.

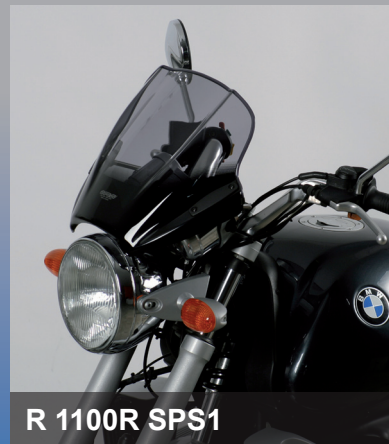
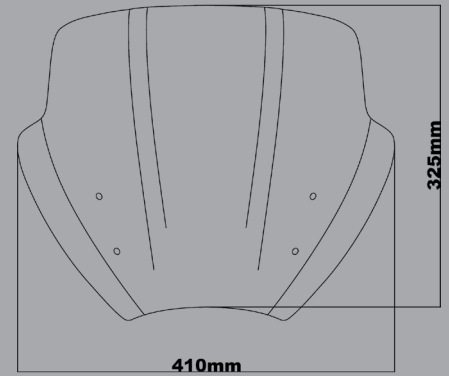

Racingscreen for Naked Bikes

Trendy Racing style now for sporty naked bikes! Available in all MRA-colors.

Racingscreen for Naked Bikes

Trendiger Racingstyle nun auch für sportliche Naked Bikes! Erhältlich in allen MRA-Farben.

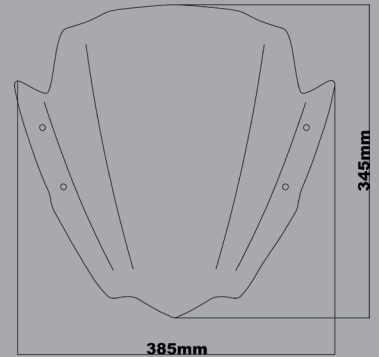
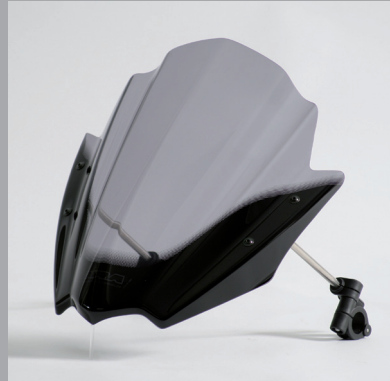

Varioscreen for Naked Bikes

This screen comes in two parts. The upper part can be adjusted by 5 cm in height. Together with the adjustment for screen angle, this allows the motorcyclist to adjust the screen to an ideal position. The air vents in the lower part ensure an air current behind the screen, giving the rider turbulence-free wind protection. Colors: clear and smoked grey.

Diese Scheibe ist zweiteilig, wobei sich der obere Teil um 5 cm in der Höhe verstellen lässt. Zusammen mit den Verstellmöglichkeiten des Scheibenwinkels lässt sich so die individuell optimale Position finden. Durch den Lufteinlass im Unterteil wird die Scheibe hinterströmt, was einen turbulenzfreien Windschutz ermöglicht. Farben: klar und rauchgrau.



R 1200R VNB1



R 1200R VNB1

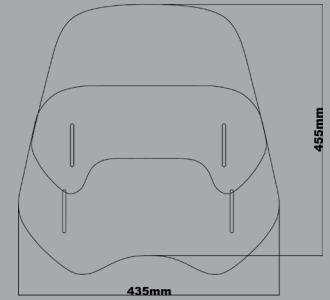

R 1200R VNB1



MT 01 VNB1

Vario-Touringscreen for Naked Bikes

Small screen with a big effect. You can fix the screen at any angle you want. The upper spoiler is adjustable in seven positions and can be fixed at your favorite position. Colors: clear and smoked grey.

Kleine Scheibe mit großer Wirkung, die stufenlos im gewünschten Winkel montiert werden kann und über einen Spoiler verfügt, der sich in sieben Positionen auf die individuellen Bedürfnisse des Fahrers einstellen lässt. Farben: klar und rauchgrau.



Brutale VTNB0

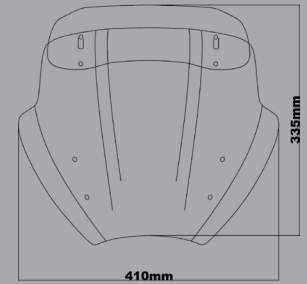
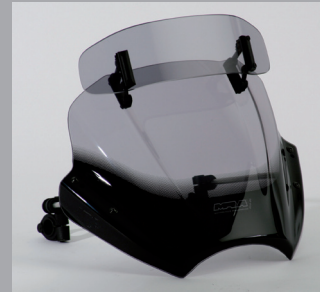

R 850R VTNB1



Brutale VTNB0



F 800R VTNB1



F 800R VTNB1

V-Flow screen – the latest MRA screen for unfaired motorcycles.

The V-shaped section in the lower part of the screen directs the air flow around and above the screen to cut turbulence and unpleasant noise. This has a highly beneficial added effect on air flow directed onto and underneath the spoiler on the VarioTouring screen and X-Creen sports models. The result: a V-Flow screen gives you effective wind protection with minimum turbulence.

V-Flow screens are available in two versions – one with a round base for classic bikes (version C) and one with a racy framed base (version Z) that follows the contours to perfection on new naked sports bikes.

Riders of shorter stature benefit most with the screen set to a shallower rake of about 45°–50°, while taller drivers should set the screen a little steeper.

V-Flow-screen (VFC/MFZ): A screen for modern naked bikes which as a result of its v-shaped profile is very effective at directing the airflow over the rider while also avoiding turbulence.

V-Flow-VT-screen (VFVTC/MFVTZ): A screen for modern naked bikes which as a result of its v-shaped profile is very effective at directing the airflow over the rider while also avoiding turbulence. The spoiler which is adjustable for seven stops lets the rider adjust the screen to their own particular requirements.

V-Flow-X-creeen Sport (VFXSC/MFXSZ): A screen for modern naked bikes which as a result of its v-shaped profile is very effective at directing the airflow over the rider while also avoiding turbulence. The small spoiler is adjustable for height, angle and distance from the screen, making this screen a real do-it-all.

Die neueste Scheibe für unverkleidete Motorräder von MRA ist die V-Flow-Screen.

Durch den V-förmigen Absatz im unteren Bereich der Scheibe wird der Luftstrom so um und über die Scheibe geleitet, dass Verwirbelungen und unangenehme Geräusche reduziert werden. Das wirkt sich auch sehr positiv auf den Luftstrom aus, der bei der VarioTouring-Screen und der X-creeen Sport auf und unter den Spoiler geleitet wird. Dadurch bietet die V-Flow-Screen guten Windschutz bei minimalen Verwirbelungen. Die V-Flow-Scheiben sind in zwei Versionen erhältlich: mit einem runden Ausschnitt am unteren Ende für klassische Bikes (Version C) oder mit einem sportlich gestaltetem Ausschnitt (Version Z), der sich hervorragend der Linienführung der neuen sportlichen Naked Bikes anpasst.

Kleinere Fahrer erzielen die beste Wirkung, wenn die Scheibe flacher steht (ca. 45°-50° Neigung). Größere Fahrer stellen die Scheibe etwas steiler.

V-Flow-screen (VFC/MFZ): Moderne Naked-Bike Scheibe, die durch den V-förmigen Absatz den Luftstrom besonders günstig um und über die Scheibe leitet, um Verwirbelungen zu vermeiden.

V-Flow-VT-screen (VFVTC/MFVTZ): Moderne Naked-Bike Scheibe, die durch den V-förmigen Absatz den Luftstrom besonders günstig um und über die Scheibe leitet, um Verwirbelungen zu vermeiden. Durch den in sieben Stufen verstellbaren Spoiler lässt sich die Strömung optimal auf die individuellen Bedürfnisse einstellen.

V-Flow-X-creeen Sport (VFXSC/MFXSZ): Moderne Naked-Bike Scheibe, die durch den V-förmigen Absatz den Luftstrom besonders günstig um und über die Scheibe leitet, um Verwirbelungen zu vermeiden. Der kleine Spoiler lässt sich in Höhe, Winkel und Abstand zur Scheibe verstellen und macht die Scheibe zum Multitalent.



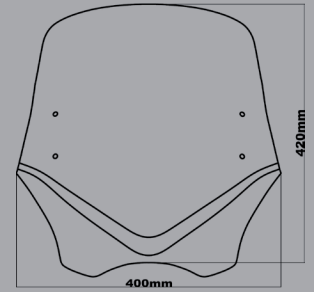

VFC

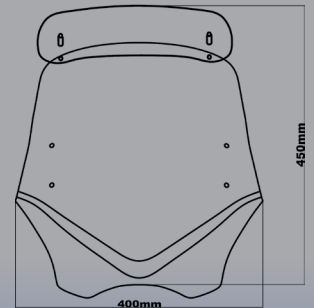

VFVTC

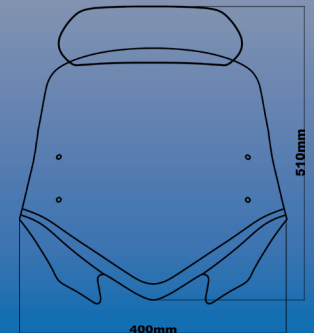

VFCS

Highwayshield

This screen's plain and simple design makes it ideal for classic naked bikes and roadsters. The size of the screen protects the whole upper body from wind and rain, right up to the helmet. Available in clear and smoked grey with black rastered lower section.

Highwayshield

Das schlichte Design der Scheibe passt ideal zu klassischen Naked Bikes und Roadster. Die Größe der Scheibe schützt den gesamten Oberkörper bis zum Helm vor Wind und Wetter. Die Scheibe ist im unteren Bereich schwarz bedruckt, was ihr eine ganz besonders edle Optik verleiht. Sie ist in klar und rauchgrau erhältlich.



R 1100R HI1

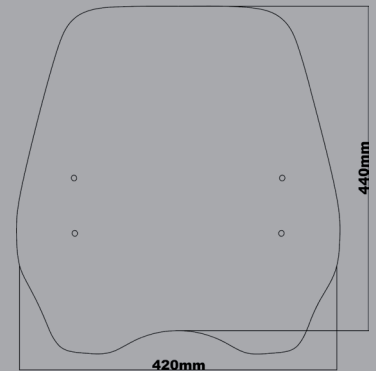

R 1100R HI1



R 1100R HI1

Customshield

The rounded design of this screen suits the style of Cruisers or Choppers. Available in clear and smoked grey.

Customshield

Diese Scheibe ist sehr rund geschnitten und daher auf die Optik von Cruiser und Chopper abgestimmt. Sie ist in klar und rauchgrau erhältlich.

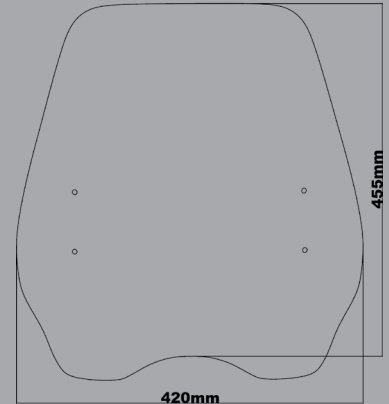







PRODUCT OVERVIEW

Produktübersicht

Color Farben	0 clear / farblos	1 grey / rauchgrau	3 blue / blau	8 black / schwarz	Color Farben	0 clear / farblos	1 grey / rauchgrau	3 blue / blau	8 black / schwarz
O					V			—	—
S					VT			—	—
T					TSA			—	—
SP					NR			—	
R					NT			—	
XCS			—	—	NVT			—	—
XCT			—	—	ST				

PRODUCT OVERVIEW

Produktübersicht

Color Farben	0 clear / farblos	1 grey / rauchgrau	3 blue / blau	8 black / schwarz	Color Farben	0 clear / farblos	1 grey / rauchgrau	3 blue / blau	8 black / schwarz
RO					VFZ			—	
ROC					VFVT			—	—
SPS					VFVTZ			—	—
RNB			—		VFXCS			—	—
VNB			—	—	VFXZS			—	—
VTNB			—		HI			—	—
VFC			—		CU			—	—



Who we are and what we do

Founded more than twenty five years ago, MRA has its roots in motorcycle racing. This led to our name:

MRA = Motorcycle Racing Accessories.

In the first few years, MRA developed and supplied products such as motorbike fairings, screens and racing seats for the racetrack. Towards the end of the eighties, MRA specialised in the exclusive development and manufacture of motorbike screens.

We have a team of 33 qualified, highly motivated technicians and experts designing and producing high-quality products using state-of-the-art production and development equipment at our 4,000 square-metre company facilities.

Naturally, we are certified according to EN ISO 9001:2000 as well as the additional KBA certificate from Germany's federal office for motorised travel.

MRA is currently one of the most famous brands in motorcycle accessories; we are represented in more than fifty countries across the world.



Wer wir sind und was wir machen

MRA wurde vor über 25 Jahren gegründet und hat seine Wurzeln im Rennsport. Daher auch der Name:

MRA = Motorcycle Racing Accessories.

In den ersten Jahren produzierte MRA Produkte wie Verkleidungen, Scheiben und Höckersitze für den Rennsport.

Ende der achtziger Jahre spezialisierte sich MRA ausschließlich auf die Entwicklung und Produktion von Motorrad-Windschutzscheiben.

Unser Team besteht aus 33 qualifizierten und hoch motivierten Technikern und Experten, die auf 4.000 m² Firmenareal mit modernsten Produktions- und Entwicklungstechniken qualitativ hochwertige Produkte entwickeln und herstellen.

Selbstverständlich sind wir DIN EN ISO 9001:2008 zertifiziert mit dem Zusatz KBA (Kraftfahrt-Bundesamt). Heute ist MRA eine der bekanntesten Marken im Motorradzubehör, mit Vertretungen in über 50 Ländern weltweit.



MRA-Team

*Faces behind the brand MRA
Gesichter hinter der Marke MRA*

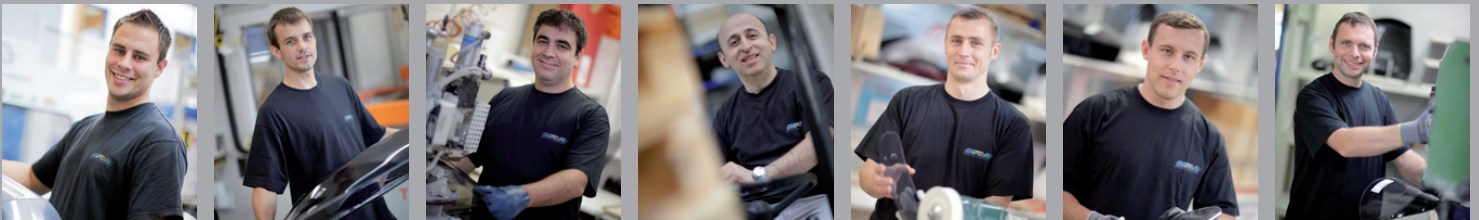

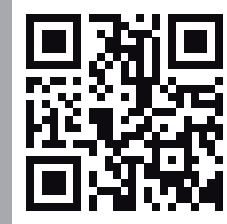



BEI UNS IST **EXPRESS** STANDARD!

BIS 14 UHR BESTELLT...

...AM NÄCHSTEN WERKTAG GELIEFERT*



*98% unserer Pakete werden am darauffolgenden Werktag innerhalb Deutschlands zugestellt.
Vorrätigkeit vorausgesetzt.



Zustellung durch



GOGREEN

Der CO₂-neutrale Versand
mit DHL

MRA goes Green

MRA sends almost all of its mail-order products via DHL - a very environmentally sound way of sending packages, with the DHL GoGreen programme. Taking part in the programme costs us five cents extra, and will effectively help us cut carbon dioxide emissions with a carbon dioxide savings certificate to confirm our contribution after a year. Naturally, we will be covering the additional charge.

MRA goes Green

MRA versendet nahezu alle Pakete mit DHL und dies Dank des DHL GoGreen-Programms mittlerweile sehr umweltfreundlich. Mit 5 Cent Mehrpreis pro Sendung können wir an dem Programm teilnehmen und sparen so effektiv CO₂ ein. Nach einem Jahr wird uns in einem Zertifikat die Einsparung an CO₂ bescheinigt. Den Mehrpreis übernehmen natürlich wir.

We have a global distribution network with importers in more than 50 countries.
Visit our webpage and find your importer sorted by country.

Wir haben ein globales Vertriebsnetzwerk mit Importeuren in mehr als 50 Ländern.
Besuchen Sie unsere Webseite und finden Sie Ihren Importeur nach Ländern sortiert.



To the list of importers

Zur Importeursliste





Every day, 500 people across the world choose a MRA-windshield, to improve their scooter or motorcycle. Their satisfaction is our greatest success.

MRA Klement GmbH

Siemens Str. 6 · D-79331 Teningen-Nimburg
Tel. +49 (0) 76 63 - 93 89 0 · Fax +49 (0) 76 63 - 93 89 11
www.mra.de · Email: info@mra.de